

Features

- Lightweight portable powered speakers with legendary QSC amplifier power and reliability
- 1000 watt Class D power modules in all models (2 x 500 W)
- Extensive DSP enhances system performance
- Attractive and professional appearance
- Rugged ABS enclosures (K8, K10 and K12)
- Tour-grade 18 gauge steel grilles
- Ergonomic handles with comfortable, non-slip grip
- 35 mm pole sockets with Tilt-Direct™ (fullrange models)
- M10 rigging points for suspended installation (fullrange models)
- K10 and K12 perform as main PA or stage monitors



The QSC K Series is quite simply The New Standard in lightweight powered loudspeaker systems. For starters, each of the four models features an all new, Pat Quilter designed 1000 watt QSC Class D power module. Next, breaking from the traditional loudspeaker paradigm, every model is fitted with the identical 1.75" HF device (fullrange models) and woofers of the same high quality for unparalleled performance, regardless of speaker size.

Extensive DSP processing is employed throughout, providing levels of sonic clarity and total output that defy the system's size and weight.

Premium-grade materials, advanced construction processes and multiple mounting and suspension options allow for a wide range of live and installed applications.

Combo XLR and 1/4" TRS inputs accept both Mic and Line Level input while a set of RCA phono inputs (except KSub) allow additional connectivity to portable MP3 players, CD players and line-level mixers. Up to three audio sources can be mixed internally and summed to a balanced output for "daisy-chaining" of multiple units. Separate direct outputs are also provided on each channel for additional output flexibility.

On-board switches provide preset EQ settings. The HF setting (fullrange models) can be set to VOCAL BOOST for additional presence in the critical mid-frequency area or FLAT for accurate reproduction of the incoming signal. The LF switch can be set to NORM, DEEP™ for

additional bass extension, or EXT SUB (fullrange models) for use with an external subwoofer. The rear panel LED switch can be set to POWER, illuminating the front-mounted LED when the unit is powered on, OFF for applications where it is not desirable to illuminate the front LED, or LIMIT which indicates to the system operator that the clip limiter circuit has been engaged during operation.

Fullrange models are housed in rugged ABS enclosures with a professional appearance that is at home in any application. ABS is a far more robust material than conventional speaker plastics and offers an additional measure of sonic clarity due to its internal rigidity. Ergonomic aluminum handles and a highly protective steel grille complete the package for ease of transport and long term durability.

The K Series fullrange models feature a unique Tilt-Direct™ pole cup mounting system. A simple turn of the dial engages a 7.5 degree downward tilt of the speaker allowing acoustic energy to be kept on the audience and off reflective surfaces for applications where maximum coverage from a high-positioned speaker is desired. Integrated M10 suspension points allow for suspended applications with a K SERIES M10 KIT (sold separately) or Yoke bracket (sold separately).

The KSub is a dual-12" bandpass design, constructed of premium birch and includes high-quality, low-noise casters. The subwoofer features a threaded pole receptacle for a positive, wobble free connection to a threaded speaker pole (included).

Remote gain control capability is offered via a potentiometer (not included) connected to the on-board Euroblock connector. In an installed application, multiple K Series speakers can be "daisy-chained" for total gain control from a single remote pot. Auto-standby mode is engaged after 5 minutes of inactivity.

Extensive DSP

- DMT™ (Directivity Matched Transition) provides for matched LF and HF coverage across the entire listening area, eliminating unnatural "dead" or "hot" frequency zones.
- Intrinsic Correction™, first featured in our high-end line-array products maps 65-75 spacially-averaged measurements to IIR and FIR filters that actively adjust time, frequency and amplitude response to a maximally flat bandpass target. The result is a speaker that behaves equally well across the entire sound field.
- DEEP™ and excursion limiting allow for extended low-frequency response by actively managing low-frequency transients without degradation of the underlying signal or adjacent frequencies.
- GuardRail™ protection, first introduced on our GX Series amplifiers protects both the amplifier module and your performance from unnatural and destructive clipping.

K Series

Specifications

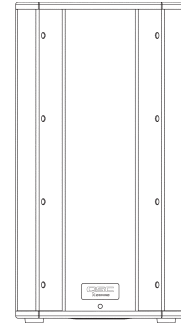
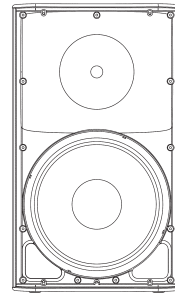
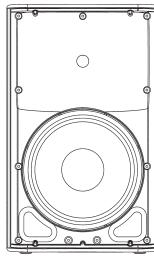
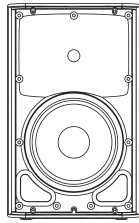

	K8	K10	K12	KSub
Configuration	Trapezoidal 2-way	Multipurpose 2-way	Multipurpose 2-way	4th Order Bandpass
Transducers				
Low-frequency	8" cone transducer	10" cone transducer	12" cone transducer	2 x 12" cone transducers
High-frequency	1.75" diaphragm compression driver	1.75" diaphragm compression driver	1.75" diaphragm compression driver	
Frequency Response (-6 dB)	66 Hz – 18 kHz	60 Hz – 18 kHz	52 Hz – 18 kHz	48 Hz – 134 Hz
Frequency Range (-10 dB)	61 Hz – 20 kHz	56 Hz – 20 kHz	48 Hz – 20 kHz	44 Hz – 148 Hz
Nominal Coverage (-6 dB)	105° conical	90° conical	75° conical	
Maximum SPL (1 meter)	127 dB peak	129 dB peak	131 dB peak	130 dB peak
Amplifiers				
Power Output	1000 W Class D (500 W LF, 500 W HF)			1000 W Class D (2 x 500 W)
Input Impedance (Ω)	XLR/ ¼": 40k balanced/20k unbalanced • XLR/ ¼" MIC mode: 2260 balanced • RCA: 10k			
Controls	Power • Gain A • Gain B • Mic/Line • LF Mode (Ext Sub/Norm/DEEP™) • HF Mode (Flat/Vocal Boost) Front LED (On/Off/Limit)			Power • Gain • LF Mode (Normal/DEEP™) • Polarity (Normal/Reverse) • Front LED (On/Off/Limit)
Indicators	Power • Signal A • Signal B • Standby • Limit • Mic			Power • Signal • Standby • Limit
Connectors	Balanced female XLR/ ¼" line/mic level input • Balanced female XLR/ ¼" line level input • Dual Balanced male XLR full range line level out • Balanced male XLR "mix" out • Stereo RCA line level input • Remote gain control • Locking IEC power connector			Dual balanced female XLR/ ¼" line level input • Dual Balanced male XLR full range line level out • Remote gain control • Locking IEC power connector
Cooling	On demand, 50 mm variable speed fan			
Amplifier Protection	Thermal limiting • Output overcurrent • Overtemperature muting • GuardRail™			
Transducer Protection	Thermal limiting • Excursion limiting			
AC Power Input	Universal power supply 85 – 265 VAC, 50 – 60 Hz			
AC Power Consumption 1/8 Power	100 VAC, 2.3 A • 120 VAC, 2.01 A • 230 VAC, 1.13 A			
Enclosure	Impact resistant ABS			Painted birch plywood
Finish	Black Paint			Black textured paint
Grille	Black powder coated 18 gauge steel			
Dimensions (HWD)	17.7" x 11" x 10.6" 450 mm x 280 mm x 269 mm	20.4" x 12.6" x 11.8" 519 mm x 320 mm x 300 mm	23.7" x 14" x 14" 603 mm x 356 mm x 356 mm	26" x 14" x 28.1" (including casters) 665 mm x 356 mm x 714 mm
Weight (Net)	27 lb (12.2 kg)	32 lb (14.5 kg)	41 lb (18.6 kg)	74 lb (33.6 kg)
Available Accessories	K8 TOTE • K8 YOKE • K SERIES M10 KIT	K10 TOTE • K10 YOKE • K SERIES M10 KIT	K12 TOTE • K12 YOKE • K SERIES M10 KIT	KSub COVER

Specifications subject to change without notice.

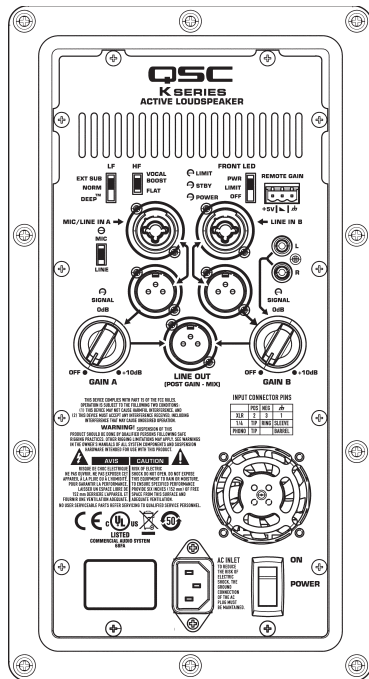

K8 | K10 | K12

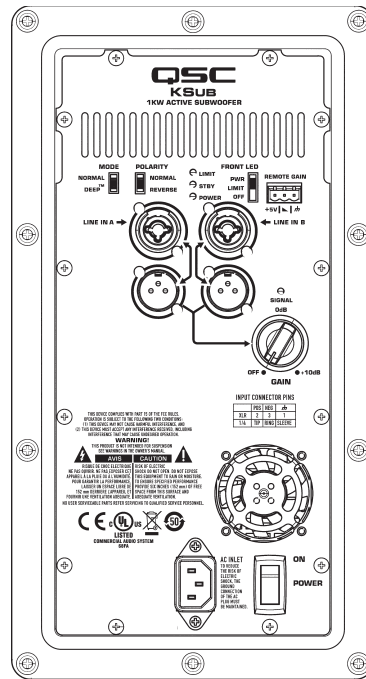

KSub



K12 Suspended from integrated M10 installation points.

K12 and K10 shown in floor monitor position.

K12 on speaker stand with Tilt-Direct™ engaged for 7.5 degree down-angle.

K8 over KSub, using K Series speaker pole (included with KSub).

K Series

Dimensions

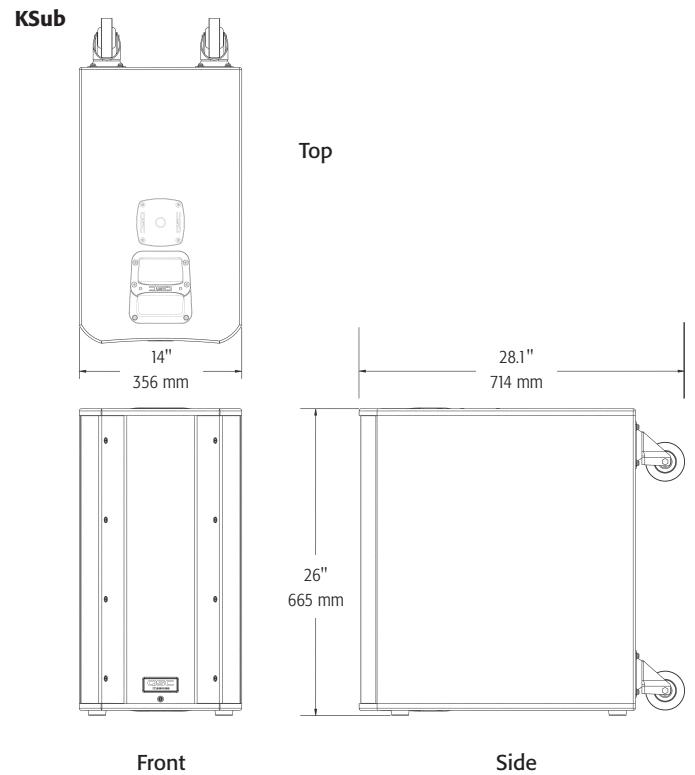
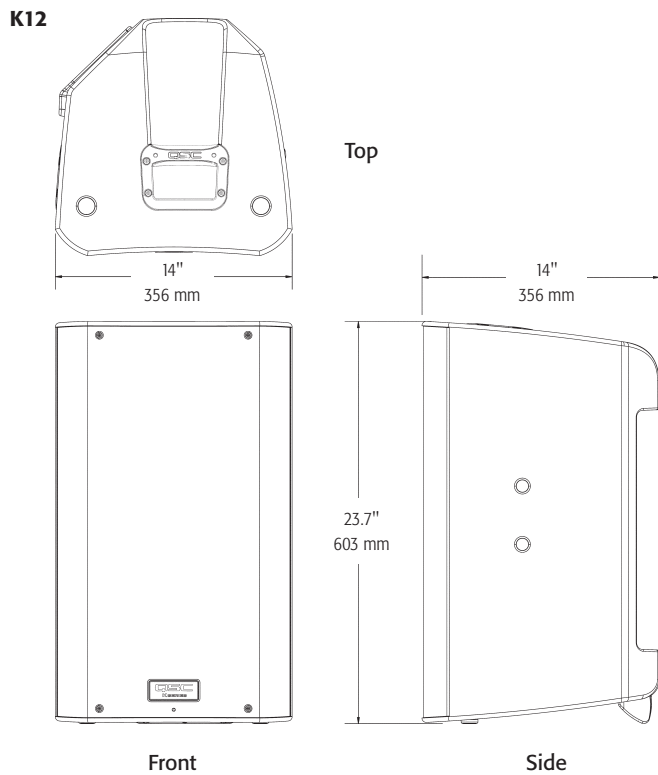
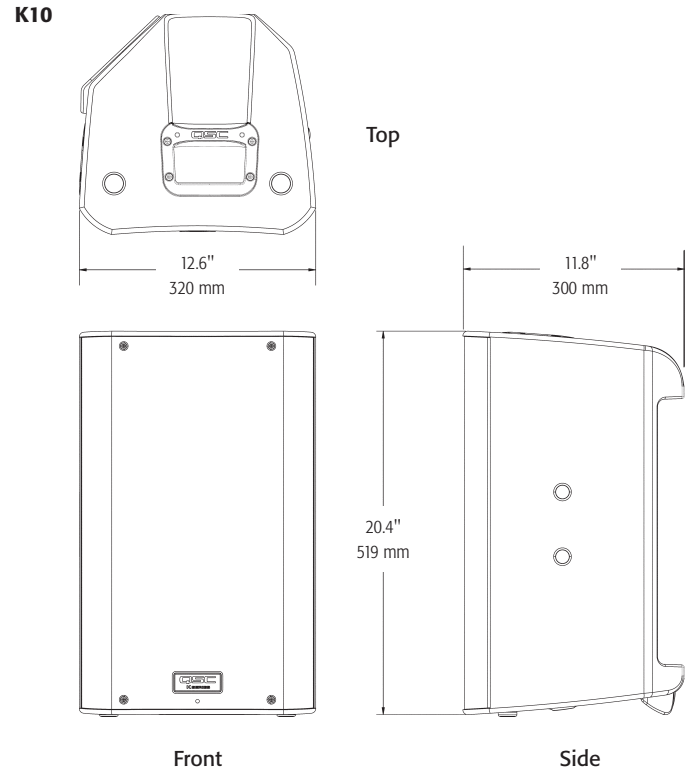
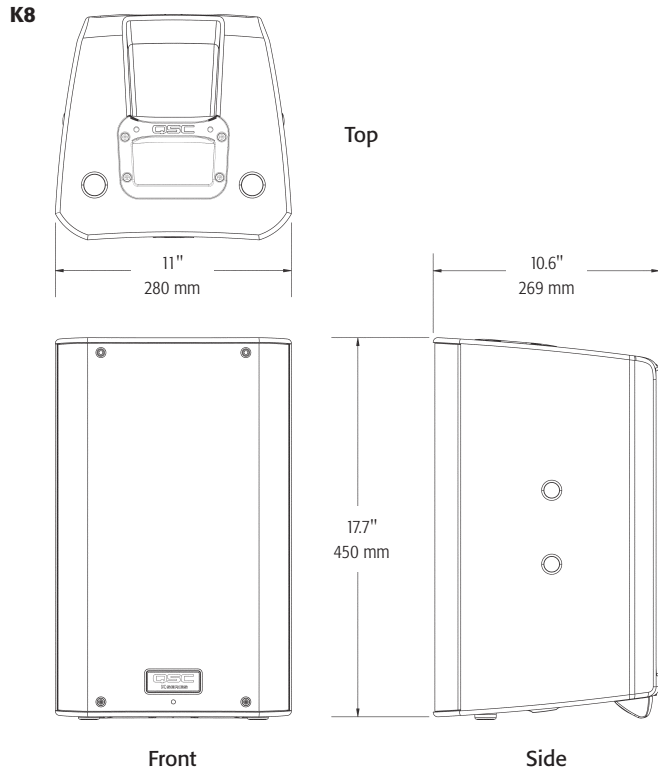

Specifications subject to change without notice.



© 2009 QSC Audio Products, LLC. All rights reserved. QSC and the QSC logo are registered trademarks of QSC Audio Products, LLC in the U.S. Patent and Trademark office and other countries. Tilt-Direct, DMT, Intrinsic Correction, DEEP and GuardRail are all trademarks of QSC Audio Products, LLC. All other trademarks are the property of their respective owners. Patents may apply or be pending.

1675 MacArthur Boulevard • Costa Mesa, CA 92626 • Ph: 800/854-4079 or 714/957-7100 • Fax: 714/754-6174

K Series Spec Sheet 05/15/09

QSC
qscaudio.com